

Math: Problem Solving and Data Analysis

Practice for the New SAT (2016)

Problem Set 2: 10 Questions

Math: Problem Solving and Data Analysis

1. A ball is attached to a pole by a string. The ball swings around the pole at a constant speed so that it remains 5 meters from the center of the pole at all times. If it takes 10 seconds to make one complete revolution around the pole, what is the distance, in meters, that the ball travels in 3 seconds?

- (A) π
 (B) 2π
 (C) 3π
 (D) 4π

2. Kiran borrows a \$560,000 loan from the bank in December. Each January, the bank charges Kiran a fee that is 7% of his remaining unpaid debt, and adds this fee to his total debt. If Kiran does not repay any of his debt during a 2-year period, what will be the sum of all his bank fees during those 2 years?

- (A) \$78,400
 (B) \$81,144
 (C) \$638,400
 (D) \$781,144

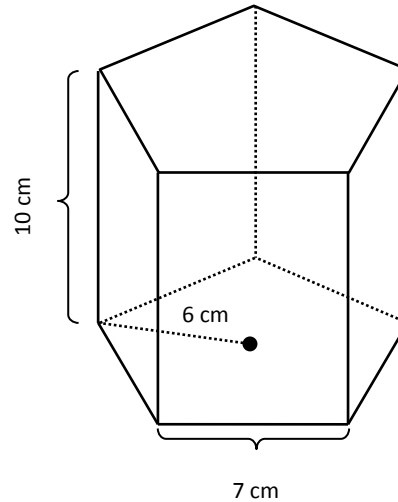

3. The figure above shows a concrete post that is shaped like a regular pentagonal prism with a height of 10 cm. Each side of the pentagonal base is 7 cm long, and the distance from a vertex to the center of the pentagonal base is 6 cm. If the density of concrete is 2.24 grams per cubic centimeter, what is the mass in kilograms of the post, rounded to the nearest tenth of a kilogram? (Density is mass divided by volume)

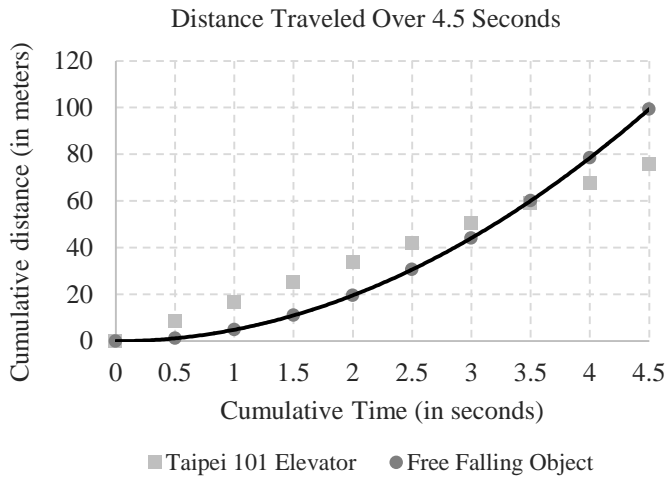

4. The Taipei 101 Elevator travels at a constant speed of 16.84 m/s. In the graph above, the elevator's distance traveled over 4.5 seconds is compared with the distance traveled by a free-falling object. A curve of best fit has been drawn to show the freefalling object's distance, d , as a function of seconds, s . Which equation most accurately represents this curve?

- (A) $d = 1.7s$
- (B) $d = s/1.7$
- (C) $d = 5.0s^2$
- (D) $d = 0.02s^3 - 0.2s^2 + 1.1s$

5. A pond contains blue and green algae. The blue algae doubles its mass every hour. The green algae has an initial mass of 8 kg, and grows at a constant rate of 0.1 kg per minute. If the masses of the two types of algae are equal after four hours, what was the initial mass of the blue algae, in kilograms?

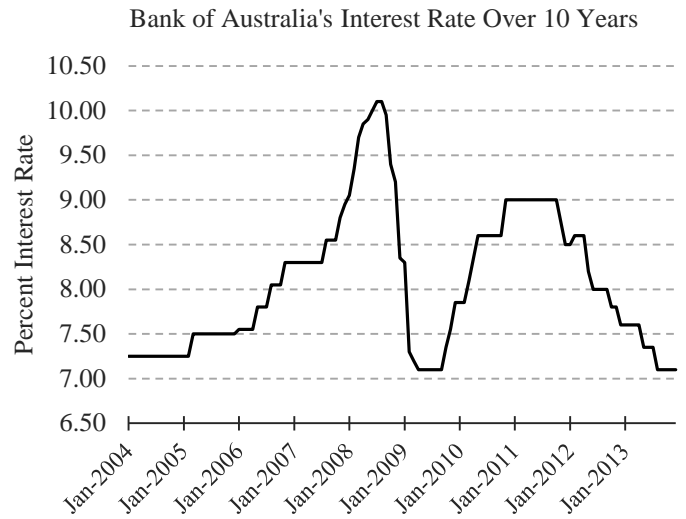

Adapted from Indicator Lending Rates, provided by the Reserve Bank of Australia.

6. The Bank of Australia's Secured Residential Term Interest Rate from 2004 to 2013 is shown in the graph above. The interest on a home loan is charged at the Bank of Australia's rate and is based on the total amount of the loan. If an Australian home was purchased in 2005 with a loan of \$450,000, approximately how much interest was charged?

- (A) \$31,500
- (B) \$32,600
- (C) \$33,800
- (D) \$34,000

FRUIT PREFERENCES AT A HIGH SCHOOL

Favorite Fruit	Number of Girls	Number of Boys
Pineapples	390	40
Bananas	0	550
Apples	50	12
Oranges	168	188
Berries	92	10
Total:	700	800

7. 800 boys and 700 girls at a high school are surveyed about their fruit preferences. Their preferences, divided by gender, are presented in the table above. If a random boy is selected from the high school, what is the percent probability that oranges will be his favorite fruit?

8. Within a population of 70 tsetse flies, the average lifespan is two months. 60 of the flies live an average of 1.5 months. What is the average standard deviation, in months, of the lifespan of the remaining flies?
- (A) 25
 (B) 5
 (C) 3
 (D) 0.5

Questions 9-10 refer to the following information:

In a peer-reviewed study of 1000 Labrador dogs, 80% could jump 1 meter in the air in 19 out of 20 attempts. There was a 2.5% margin of error when measuring the height of jumps.

9. Julia wants to know her Labrador's chances of jumping 1 meter in the air. Based on the peer-reviewed study, which one of the following statements could be correct?
- (A) Julia's Labrador has a 95% chance of jumping 1 meter in the air.
 (B) Julia's Labrador has an 80% chance of jumping 1 meter in the air.
 (C) Julia's Labrador has an 80% chance of jumping 1 meter in the air 95% of the time it jumps.
 (D) Julia's Labrador has an 80% chance of jumping at least 0.975 meters in the air 95% of the time it jumps.
10. Hans owns a bulldog whose weight and height are almost exactly half of the weight and height of Julia's Labrador. Given this information, which of the following statements is true?
- (A) Hans's bulldog would have about a 40% chance of jumping at least 0.975 meters in the air.
 (B) Hans's bulldog would have an 80% chance of jumping 0.5 meters in the air.
 (C) Hans's bulldog would have a 95% chance of jumping 0.5 meters in the air.
 (D) The peer-reviewed study cannot be used to predict the jumping height of Hans's bulldog.

Summary

10 Questions	
2 Easy, 4 Medium, 4 Hard	Estimated Time: 30 minutes

Answers

Answers	Difficulty	Topic	Other Topics
1) C	Medium	Take a given ratio and solve a multistep problem.	
2) B	Hard	Take a given percentage and solve a multistep problem.	
3) 1.9	Hard, Multi-point	Multistep problems involving measurement quantities. Use the concept of density to solve a multistep problem.	Solve problems using volume formulas. Calculate missing information using the Pythagorean theorem and ratios.
4) C	Medium	Given a scatterplot, use the line or curve of best fit to make a prediction.	
5) 2	Medium	Compare linear growth with exponential growth.	
6) B	Easy	Use the relationship between two variables to investigate key features of the graph.	
7) 23.5	Easy	Use two-way tables to summarize categorical data and calculate conditional probability.	
8) C	Hard	Calculate measure of center and spread for a give set of data.	
9) D	Hard,	Make inferences about	

	Multi-part	population parameters based on sample data.	
10) D	Medium, Multi-part	Evaluate reports to make inferences, justify conclusions, and determine appropriateness of data collection methods.	